

# Stromag TRI-R Highly-Flexible Ring Coupling



# Stromag TRI-R Highly-Flexible Ring Coupling

## Special designs

### TEF...F – RR

To connect a flywheel or equivalent to a flanged shaft.  
The internal pendulum bearing allows a cardanic motion.

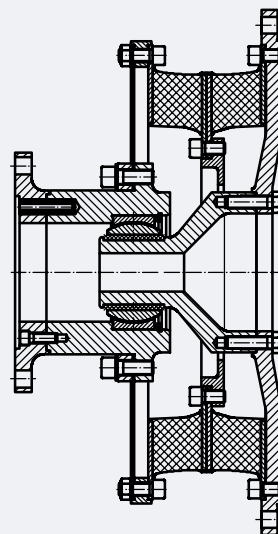

DD-\_886148

### TEF...W – R / KHR

2 in 1 combined with a hydraulic clutch to connect two machines from shaft to shaft.

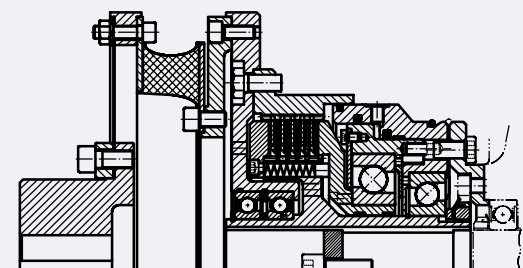

DD-\_886284

### TEF...W – RR

Combined with a pneumatically acutated conical clutch to connect a flywheel or equivalent to a shaft.

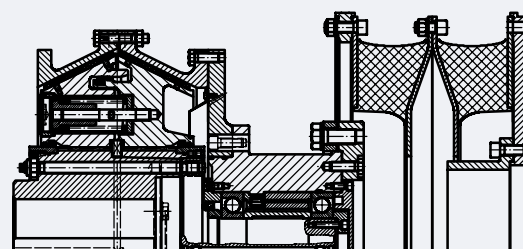

DD-\_886283

# Stromag TRI-R Highly-Flexible Ring Coupling

---

This catalogue for Stromag TRI-R couplings cancels and replaces all former editions.

We reserve the right to modify the dimensions and constructions.

Stromag products comply with the Quality Standard to DIN ISO 9001.

<b>Content</b>	<b>Page</b>
Stromag TRI-R coupling concept	<b>4</b>
Instruction for the designer	
• Use in potentially explosive environments	<b>5</b>
• Classification rules	
• Fail-safe device	
Instructions on choosing the coupling size	<b>6</b>
Installation instructions and scope of delivery	
• Storing flexible rubber elements	<b>7</b>
Stromag TRI-R Output table	<b>8</b>
TEF and TEW Series	<b>10</b>
Stromag TRI-R Coupling characteristics	<b>22</b>
Coupling design, question sheet	<b>25</b>
Use in potentially explosive environments, question sheet	<b>26</b>

# Stromag TRI-R Highly-Flexible Ring Coupling

## Stromag TRI-R coupling concept

Stromag TRI-R couplings are highly-flexible rubber couplings with linear spring characteristic ideal for diesel engine and resiliently mounted drives.

The torque range of this series is 1150 to 63,000 Nm. With couplings up to 16,000 Nm, the outer connection dimensions conform as a standard to the flywheel connections of the SAE standard J620. The larger couplings are basically designed with metric flywheel connections.

Stromag TRI-R couplings combine a ring element of rubber-flexible material and a diaphragm of spring steel. The ring element is torsionally flexible and assures a radial flexibility.

The diaphragm assures the axial flexibility, so that the coupling allows offset in all directions.

Each Stromag TRI-R size comes with a range of elastomer qualities and torsional stiffnesses. These allow precise configurations for drives susceptible to torsional vibrations. The Stromag coupling TRI-R can also be supplied in multi-row combinations of ring elements.

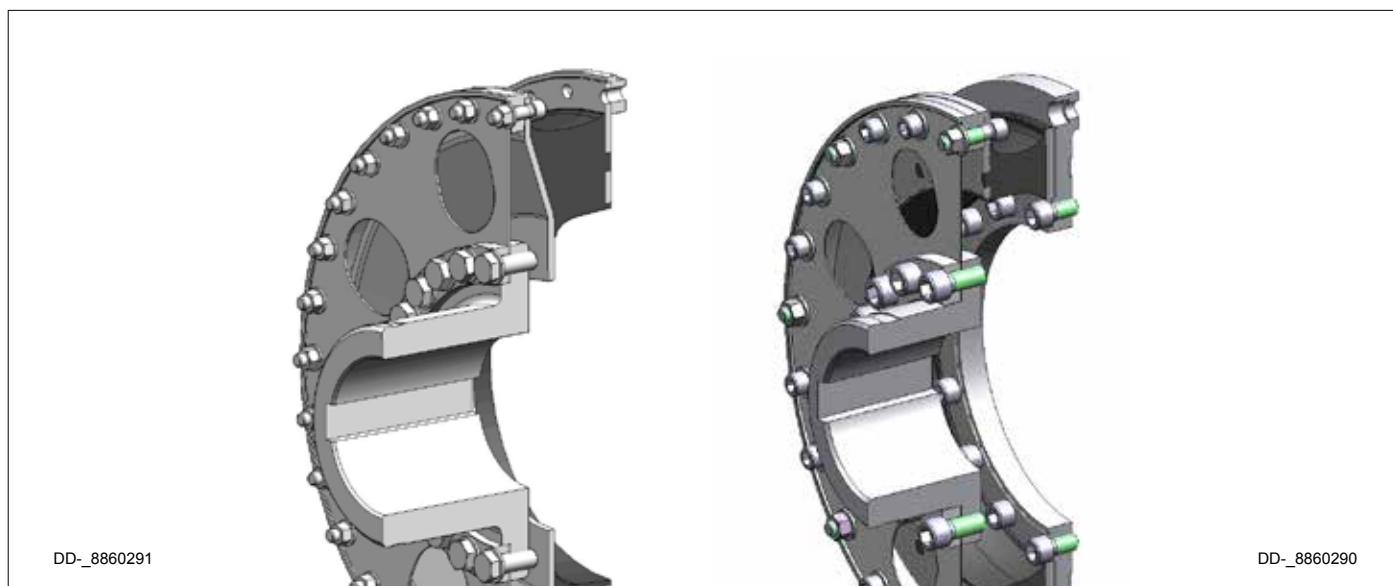

## Type of application

Stromag TRI-R couplings are designed for use on piston engines. The ring element can be bolted directly to the flywheel of an engine. The connection of two shafts or two flanges is also possible when executed accordingly.

Due to its high axial and radial offset capacity, the coupling is ideal for applications with resiliently mounted drives. A good structure-borne noise insulation is achieved by the great rubber volume.

# Stromag TRI-R Highly-Flexible Ring Coupling

## Instruction for the designer

The metal parts of Stromag TRI-R coupling are made of steel. The ring element is made of different elastomer materials in various torsional stiffnesses.

The design with natural rubber (NR) can be used within the temperature range from – 50 °C up to +80 °C.

Damping work may cause the flexible element to reach temperatures higher than ambient. This must be considered when the coupling is to be fitted with a guard or cowl, and adequate ventilation and heat dissipation must be provided.

The Stromag TRI-R coupling can be delivered with EN 10204 acceptance as defined in the classification societies rules.

### Use in potentially explosive environments

The coupling conforms to the requirements under Directive 2014/34/EU and can be used as follows:

- a. Zone 1 (gas, Category 2G) in Groups IIA, IIB, and IIC, T4
- b. Zone 2 (gas, Category 3G) in Groups IIA, IIB, and IIC, T4
- c. Zone 22 (dust, Category 3D) for dusts with a minimum ignition energy > 3 mJ, T 125 °C

The Stromag TRI-R coupling compliance with the requirements for each of these zones / categories is documented in the form of the following codes on our products:

#### Use in gas atmospheres:

 II 2G c T4 or II 3G c T4

#### Use in dust atmospheres:

 II 3D c 125 °C

Use in potentially explosive environments must be based on the request form annexed to this catalogue.

## Classification rules

For survey of the coupling by a classification society, the regulations of the society have to be adhered to. The coupling characteristics may differ from the definitions given in this catalogue. Accordingly prepared data sheets are available on request.

Some classification societies prescribe fail-safe devices for marine main drives.

# Stromag TRI-R Highly-Flexible Ring Coupling

## Fail-safe device

Stromag TRI-R couplings are available with an fail-safe device. A rupture in the flexible element causes claws to intermesh, forming a torsionally rigid, backlash connection between the drive and output sides. Temporary emergency operation is possible with limited torque. The permissible torques and speeds must be calculated separately on the basis of torsional vibrations transferred via a torsionally rigid structure.



## Instructions on choosing the coupling size

The static and dynamic characteristics of Stromag TRI-R couplings are available. These can help to choose the suitable coupling size for the specific application. The key factors are the loads induced by the transferred power and torsional vibrations. Stationary operating modes must be based on  $T_{KN}$ ,  $T_{KW}$ , and  $P_{KV}$ , nonstationary operating modes on the  $T_{Kmax}$  values.

Stromag GmbH departments can provide support, specifically in calculating the torsional vibrations. We therefore ask you to complete and send us the question sheet annexed to this catalogue.

As a rule, flexible couplings are a safety feature in the form of a predetermined breaking point on a drive train. Hence, overloading a drive train generally leads to failure of the flexible coupling element. This behaviour is intentional and protects the entire system from unforeseen damage. Any consequential damage arising from this safety function of the coupling must be considered in advance by the system designer and monitored or eliminated with suitable measures.

# Stromag TRI-R Highly-Flexible Ring Coupling

## Installation instructions and scope of delivery

Stromag TRI-R coupling can be bolted directly to the flywheel of the engine through the ring element (3) and the connection flange (4). The counterside of the ring element (3) is bolted to the diaphragm (8) through the center ring (6).

The diaphragm (8) transmits the torque to a connected machine, a gearbox, or similar through the connection with the pressure ring (7) via the hub (1).

The ring element of size 12 is split into 2 halves in order to assure a simple radial mounting.

The delivery extent of the Stromag TRI-R coupling in standard execution comprises:

- 1 = Hub
- 3 = Ring element
- 4 = Connection flange
- 6 = Center ring
- 7 = Pressure ring
- 8 = Diaphragm
- 9, 10, 11, 15 = Screws
- 12 = Nut
- 14 = Washer

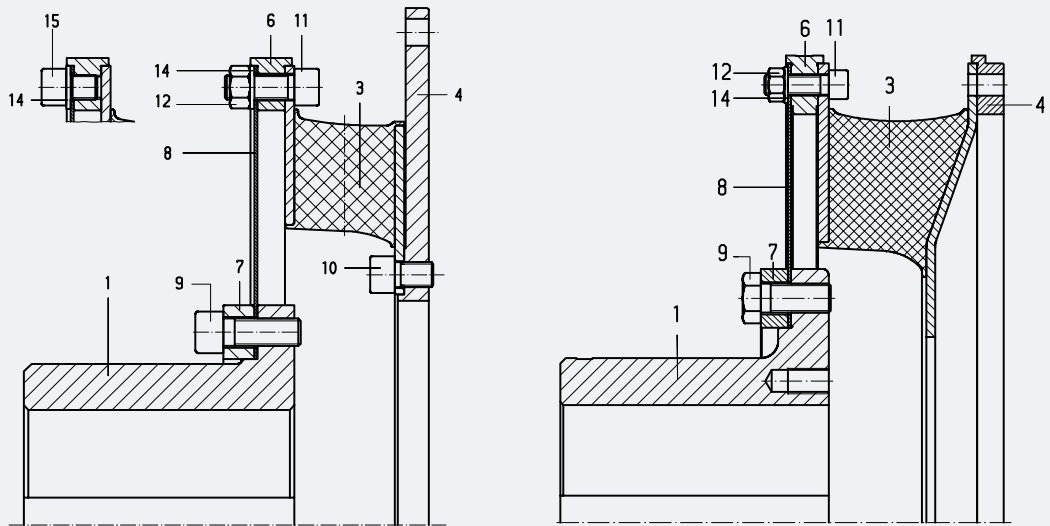

## Storing flexible rubber elements

When stored properly, flexible rubber elements retain their properties over several years. It is essential here that the stored parts are protected against oxygen, ozone, light, heat, moisture, and solvents. Solvents, fuels, lubricants, chemicals, acids, disinfectants, and similar may not be stored in the same room. The storage temperature should not be lower than +10°C and not higher than +25°C.

All UV light sources are harmful and must be avoided. Equipment that generates ozone, e.g. light sources and electric motors, must be kept away from the storage location. The relative air humidity should not exceed 65%.

Further details can be taken from DIN 7716 und ISO 2230.

# Stromag TRI-R Highly-Flexible Ring Coupling

## Output table

Coupling size	Nominal torque	Maximum torque		Adm. alternating torque	Adm. speed	Adm. axial displacement
	$T_{KN}$ Nm	$T_{Kmax1}$ 1) Nm	$T_{Kmax2}$ 2) Nm	$T_{KW}$ Nm	$n_{max}$ min <sup>-1</sup>	$\Delta K_a$ 3) mm
<b>311 R</b>	1300	1950	3900	325	3800	3
<b>312 R</b>	1700	2550	5100	425	3800	3
<b>313 R</b>	2000	3000	6000	500	3800	3
<b>321 R</b>	1800	2700	5400	450	3800	3
<b>322 R</b>	2200	3300	6600	550	3800	3
<b>323 R</b>	2600	3900	7800	650	3800	3
<b>411 R</b>	2300	3450	6900	575	2800	4
<b>412 R</b>	3000	4500	9000	750	2800	4
<b>413 R</b>	4000	6000	12000	1000	2800	4
<b>421 R</b>	3500	5250	10500	875	2800	4
<b>422 R</b>	3800	5700	11400	950	2800	4
<b>423 R</b>	5200	7800	15600	1300	2800	4
<b>431 R</b>	4400	6600	13200	1100	2800	4
<b>432 R</b>	5600	8400	16800	1400	2800	4
<b>433 R</b>	6700	10050	20100	1675	2800	4
<b>511 R</b>	7200	10800	21600	1800	2300	5
<b>512 R</b>	9400	14100	28200	2350	2300	5
<b>513 R</b>	11400	17100	34200	2850	2300	5
<b>521 R</b>	9800	14700	29400	2450	2300	5
<b>522 R</b>	13000	19500	39000	3250	2300	5
<b>523 R</b>	14800	22200	44400	3700	2300	5
<b>641 R</b>	16000	24000	48000	4000	2100	6
<b>642 R</b>	16000	24000	48000	4000	2100	6
<b>643 R</b>	16000	24000	48000	4000	2100	6
<b>741 R</b>	20000	30000	60000	5000	2000	6
<b>742 R</b>	20000	30000	60000	5000	2000	6
<b>743 R</b>	20000	30000	60000	5000	2000	6
<b>841 R</b>	25000	37500	75000	6250	1900	6
<b>842 R</b>	25000	37500	75000	6250	1900	6
<b>843 R</b>	25000	37500	75000	6250	1900	6
<b>941 R</b>	31500	47250	94500	7875	1750	6
<b>942 R</b>	31500	47250	94500	7875	1750	6
<b>943 R</b>	31500	47250	94500	7875	1750	6
<b>1041 R</b>	40000	60000	120000	10000	1600	6
<b>1042 R</b>	40000	60000	120000	10000	1600	6
<b>1043 R</b>	40000	60000	120000	10000	1600	6
<b>1141 R</b>	50000	75000	150000	12500	1500	6
<b>1142 R</b>	50000	75000	150000	12500	1500	6
<b>1143 R</b>	50000	75000	150000	12500	1500	6
<b>1241 R</b>	63000	94750	189000	15800	1000	7
<b>1242 R</b>	63000	94750	189000	15800	1000	7
<b>1243 R</b>	63000	94750	189000	15800	1000	7

1) for transient repetitive vibrations during start/stop, clutching etc.

2) for rare occasional peak loads, e.g. short circuits in generators

3) dyn. axial displacement  $\Delta K_{a\ dyn} = 0.33 \cdot \Delta K_a$

4) at  $n_{max} = 600\ rpm$ , for higher speed ratings:

$$\Delta K_r(n) = \sqrt{\frac{600\ rpm}{n}} \cdot \Delta K_r$$

5) at:  $TW = 0.2 \cdot T_{KN}$ ;  $T = 0.8 \cdot T_{KN}$ ;  $f = 10\ Hz$ ;  $\vartheta = 30^\circ C$



# Stromag TRI-R Highly-Flexible Ring Coupling

Axial reaction force	Adm. radial displacement	Adm. max. radial displacement	Radial stiffness	Torsional stiffness	Relative damping	Adm. damping power
$F_a$ 8)	$\Delta K_r$ 4) 6)	$\Delta K_{rmax}$ 6)	$C_r$ 7)	$C_{Tdyn}$ 5) 7)	$\Psi$ 5) 7)	$P_{KV60}$ 6) 9)
kN	mm	mm	kN/mm	kNm/rad		W
0.26	3	6	0.38	6.9	0.8	260
0.26	3	6	0.52	9.5	1.0	260
0.26	2	4	0.75	13.5	1.1	260
0.26	3	6	0.49	10.5	0.8	340
0.26	3	6	0.75	14.5	1.0	340
0.26	2	4	1.0	20.0	1.1	340
0.27	4	8	0.59	19.0	0.8	360
0.27	4	8	0.72	28.5	1.0	360
0.27	3	6	1.1	34.5	1.1	360
0.27	4	8	0.78	25.5	0.8	440
0.27	4	8	1.0	34.5	1.0	440
0.27	3	6	1.2	42.0	1.1	440
0.27	4	8	0.94	32.5	0.8	510
0.27	4	8	1.1	42.5	1.0	510
0.27	3	6	1.7	57.5	1.1	510
0.45	5	10	1.1	60.0	0.8	580
0.45	5	10	1.4	82.5	1.0	580
0.45	4	8	2.0	105.0	1.1	580
0.45	5	10	1.8	90.0	0.8	630
0.45	5	10	1.9	100	1.0	630
0.45	4	8	2.4	146	1.1	630
0.60	6	12	1.4	85	0.7	680
0.60	6	12	2.0	120	1.0	680
0.60	6	12	3.6	210	1.1	680
0.90	6	12	1.6	105	0.7	800
0.90	6	12	2.4	160	1.0	800
0.90	6	12	4.2	275	1.1	800
0.92	6	12	1.6	125	0.7	900
0.92	6	12	2.7	210	1.0	900
0.92	6	12	4.5	345	1.1	900
0.92	6	12	1.9	170	0.7	960
0.92	6	12	3.1	275	1.0	960
0.92	6	12	5.1	460	1.1	960
1.1	7	14	2.0	210	0.7	1080
1.1	7	14	3.3	350	1.0	1080
1.1	7	14	5.6	590	1.1	1080
1.1	7	14	2.2	275	0.7	1160
1.1	7	14	3.6	440	1.0	1160
1.1	7	14	6.0	740	1.1	1160
1.6	9	18	2.5	350	0.7	1240
1.6	9	18	4.0	550	1.0	1240
1.6	9	18	6.8	950	1.1	1240

6) For coupling temperatures exceeding 30°C, this value must be reduced by the temperature factor

7) Tolerances until ±15 % related to the material are possible

8) at shaft offset  $\Delta W_a = 1$  mm

9) The value  $P_{KV60}$  describes the damping power to be absorbed over 1 hour.

Permanently absorbed damping power  $P_{KV\infty} = 0.5 \cdot P_{KV60}$

# Stromag TRI-R Highly-Flexible Ring Coupling

## TEF...W – R Series

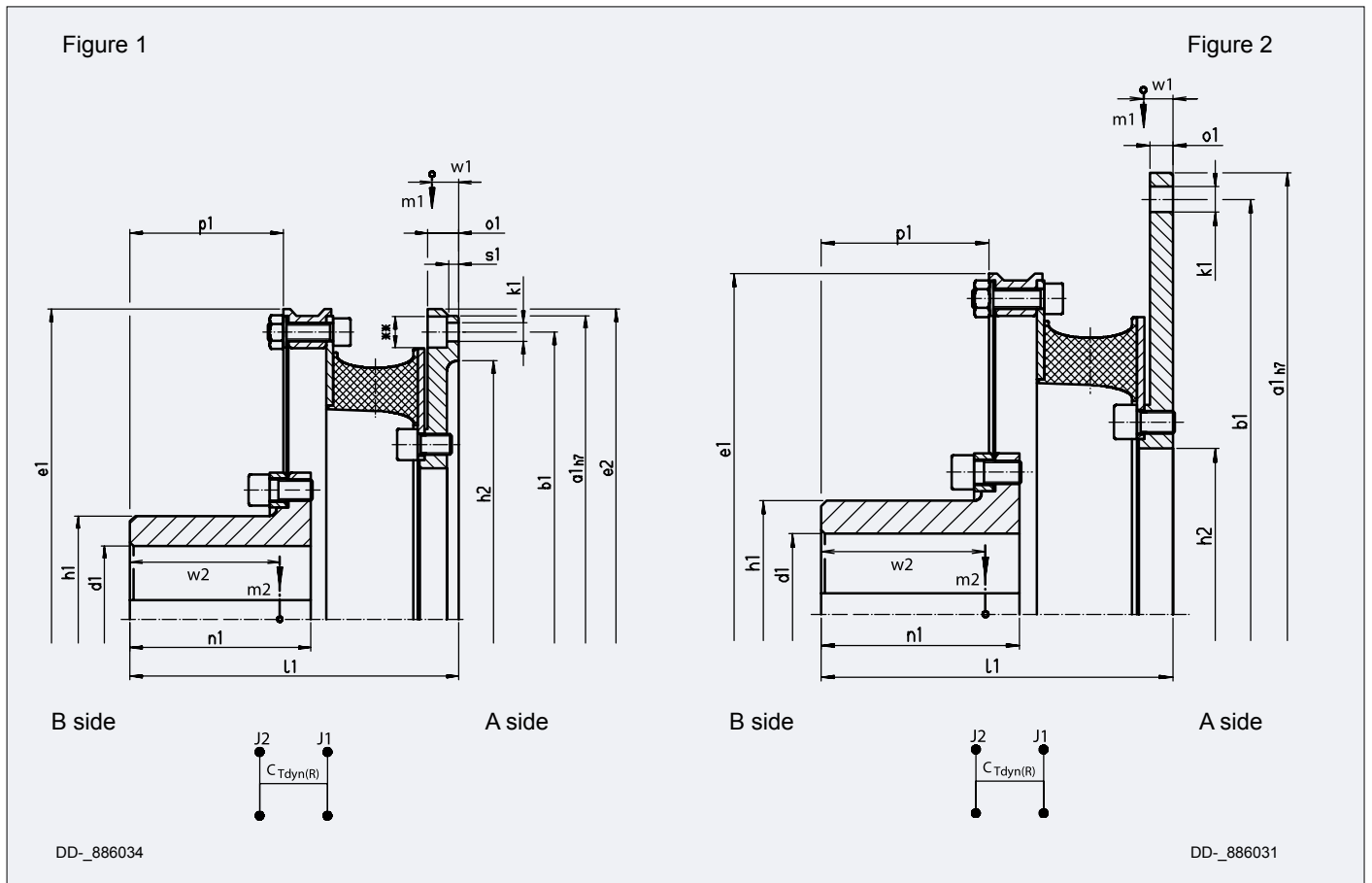

Coupling size		31		32		41		42		
Flywheel Connection to SAE J620		11,5"	14"	11,5"	14"	14"	16"	14"	16"	18"
Figure		1	2	1	2	1	2	1	2	2
Diameter mm	d <sub>1 vor</sub>	30	30	30	30	35	35	35	35	35
	d <sub>1 max</sub>	85	85	85	85	120	120	120	120	120
	a <sub>1</sub>	352.4	466.7	352.4	466.7	466.7	517.5	466.7	517.5	571.5
	b <sub>1</sub>	333.4	438.2	333.4	438.2	438.2	489	438.2	489	542.9
	e <sub>1</sub>	360	360	360	360	475	475	475	475	475
	e <sub>2</sub>	360	-	360	-	-	-	-	-	-
	h <sub>1</sub>	120	120	120	120	168	168	168	168	168
	h <sub>2</sub>	300	175	300	175	405	245	405	245	245
Lengths mm	k <sub>1</sub>	8xØ11**	8xØ13.5	8xØ11**	8xØ13.5	8xØ13.5**	8xØ13.5	8xØ13.5**	8xØ13.5	12xØ17.5
	l <sub>1</sub>	191	186	191	186	195	188	195	188	188
	n <sub>1</sub>	105	105	105	105	105	105	105	105	105
	p <sub>1</sub>	89	89	89	89	83	83	83	83	83
	o <sub>1</sub>	18	12	18	12	22	15	22	15	15
	s <sub>1</sub>	6	-	6	-	-	-	-	-	-
	W <sub>1</sub>	15.5	9	16	9	18	11.5	18.5	12	11.5
	W <sub>2</sub> *	87	87	87.5	87.5	84	84	84.5	84.5	84.5
Masses kg	m <sub>1</sub>	10.8	16.6	10.9	16.7	22.2	24.5	22.5	24.8	30.3
	m <sub>2</sub> *	13.4	13.4	13.5	13.5	27.9	27.9	28.2	28.2	28.2
Mass mom. of inertia kgm <sup>2</sup>	J <sub>1</sub>	0.216	0.474	0.220	0.478	0.770	0.939	0.780	0.950	1.354
	J <sub>2</sub> *	0.192	0.192	0.195	0.195	0.691	0.691	0.701	0.701	0.701

\*) at max. bore diameter. Other coupling sizes on request

\*\*) + countersunk for cyl. screws ISO 4762

Dimensions and construction subject to change

# Stromag TRI-R Highly-Flexible Ring Coupling

## TEF..W – R Series

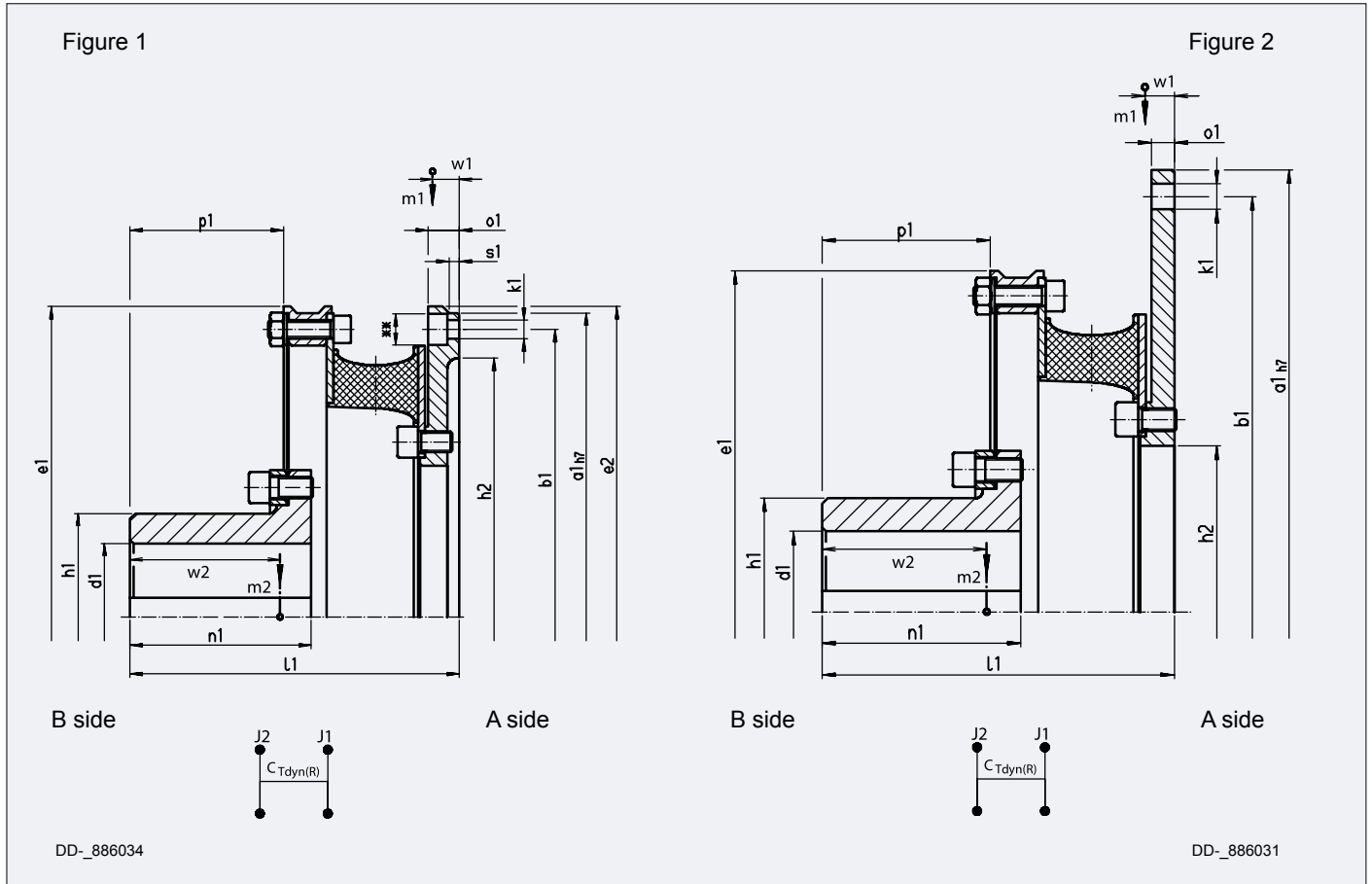

Coupling size		43			51		52		
Flywheel Connection to SAE J620		14"	16"	18"	18"	21"	18"	21"	24"
Figure		1	2	2	1	2	1	2	2
Diameter mm	$d_{1\text{vor}}$	35	35	35	55	55	55	55	55
	$d_{1\text{max}}$	120	120	120	150	150	150	150	150
	$a_1$	466.7	517.5	571.5	571.5	673.1	571.5	673.1	733.4
	$b_1$	438.2	489	542.9	542.9	641.4	542.9	641.4	692.2
	$e_1$	475	475	475	608	608	608	608	608
	$e_2$	-	-	-	580	-	580	-	-
	$h_1$	168	168	168	210	210	210	210	210
	$h_2$	405	245	245	505	292	505	292	292
Lengths mm	$k_1$	8xØ13.5**	8xØ13.5	12xØ17.5	12xØ17.5**	12xØ17.5	12xØ17.5**	12xØ17.5	12xØ20
	$l_1$	195	188	188	289	279	272	262	262
	$n_1$	105	105	105	175	175	175	175	175
	$p_1$	83	83	83	146.5	146.5	146.5	146.5	146.5
	$o_1$	22	15	15	25	15	25	15	15
	$s_1$	-	-	-	7	-	7	-	-
	$W_1$	19	12.5	11.5	22	13	23	13.5	12.5
	$W_2^*$	85	85	85	142	142	134	134	134
Masses kg	$m_1$	22.7	25	30.5	38.2	44.4	39	45.2	53
	$m_2^*$	28.4	28.4	28.4	67.9	67.9	58.2	58.2	58.2
Mass mom. of inertia kgm <sup>2</sup>	$J_1$	0.790	0.959	1.364	2.034	2.763	2.088	2.817	3.789
	$J_2^*$	0.711	0.711	0.711	2.751	2.751	2.025	2.025	2.025

\*) at max. bore diameter. Other coupling sizes on request

\*\*) + countersunk for cyl. screws ISO 4762

Dimensions and construction subject to change

# Stromag TRI-R Highly-Flexible Ring Coupling

## TEF...W – R Series

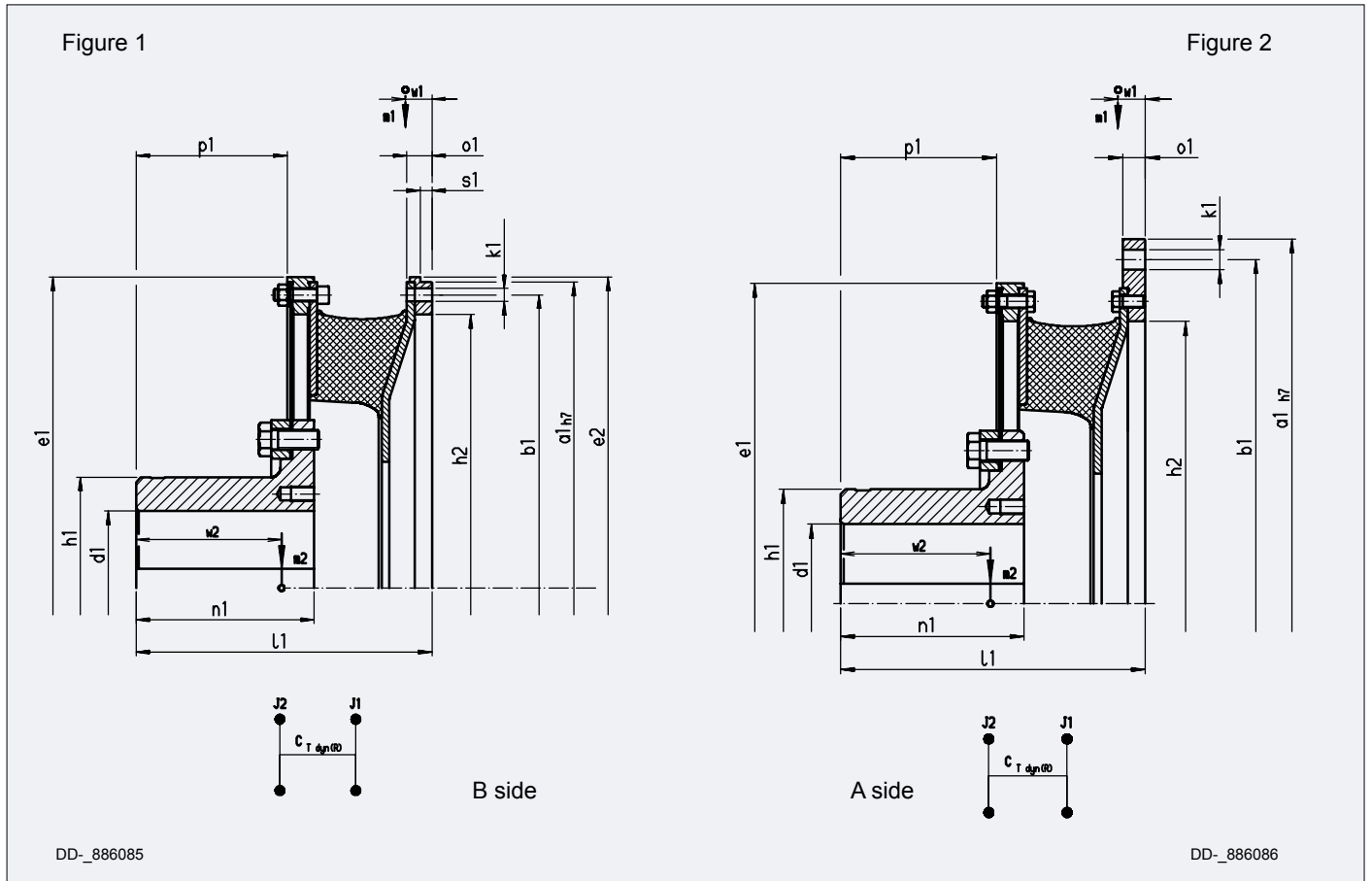

Coupling size		64				74		
Flywheel Connection to SAE J620		metr.	18"	21"	24"	metr.	21"	24"
Figure		1	2	2	2	1	1	2
Diameter mm	$d_{1\text{vor}}$	80	80	80	80	85	85	85
	$d_{1\text{max}}$	160	160	160	160	170	170	170
	$a_1$	635	571.5	673.1	733.4	680	673.1	733.4
	$b_1$	608	542.9	641.4	692.2	650	641.4	692.2
	$e_1$	645	645	645	645	692	692	692
	$e_2$	645	645	–	–	692	692	–
	$h_1$	230	230	230	230	240	240	240
	$h_2$	568	490	568	568	610	600	610
Lengths mm	$k_1$	32xØ13.5	12xØ17.5	12xØ17.5	12xØ20	32xØ15.5	12xØ17.5	12xØ20
	$l_1$	307	315	315	307	332	332	342
	$n_1$	185	185	185	185	200	200	200
	$p_1$	157	157	157	157	170	170	170
	$o_1$	26	15***	8.5**	23	28	28	10.5**
	$s_1$	12	8	–	–	12	12	–
	$W_{1*}$	27.5	35.5	35	33	30	40	38
	$W_{2*}$	151	145.5	145.5	145.5	165.5	159	159
Masses kg	$m_1$	28.3	46.2	45.9	39.2	34.9	41.2	60.9
	$m_{2*}$	86.7	81.8	81.8	81.8	102.9	97.4	97.4
Mass mom. of inertia kgm <sup>2</sup>	$J_1$	2.123	3.192	3.567	3.276	2.982	3.228	5.632
	$J_{2*}$	3.317	3.164	3.164	3.164	4.614	4.426	4.426

\*) at max. bore diameter. Other coupling sizes on request

\*\*) + countersunk for cyl. screws ISO 4762

\*\*\*) + countersunk for hexagon screw ISO 4017

Dimensions and construction subject to change

# Stromag TRI-R Highly-Flexible Ring Coupling

## TEF..W – R Series

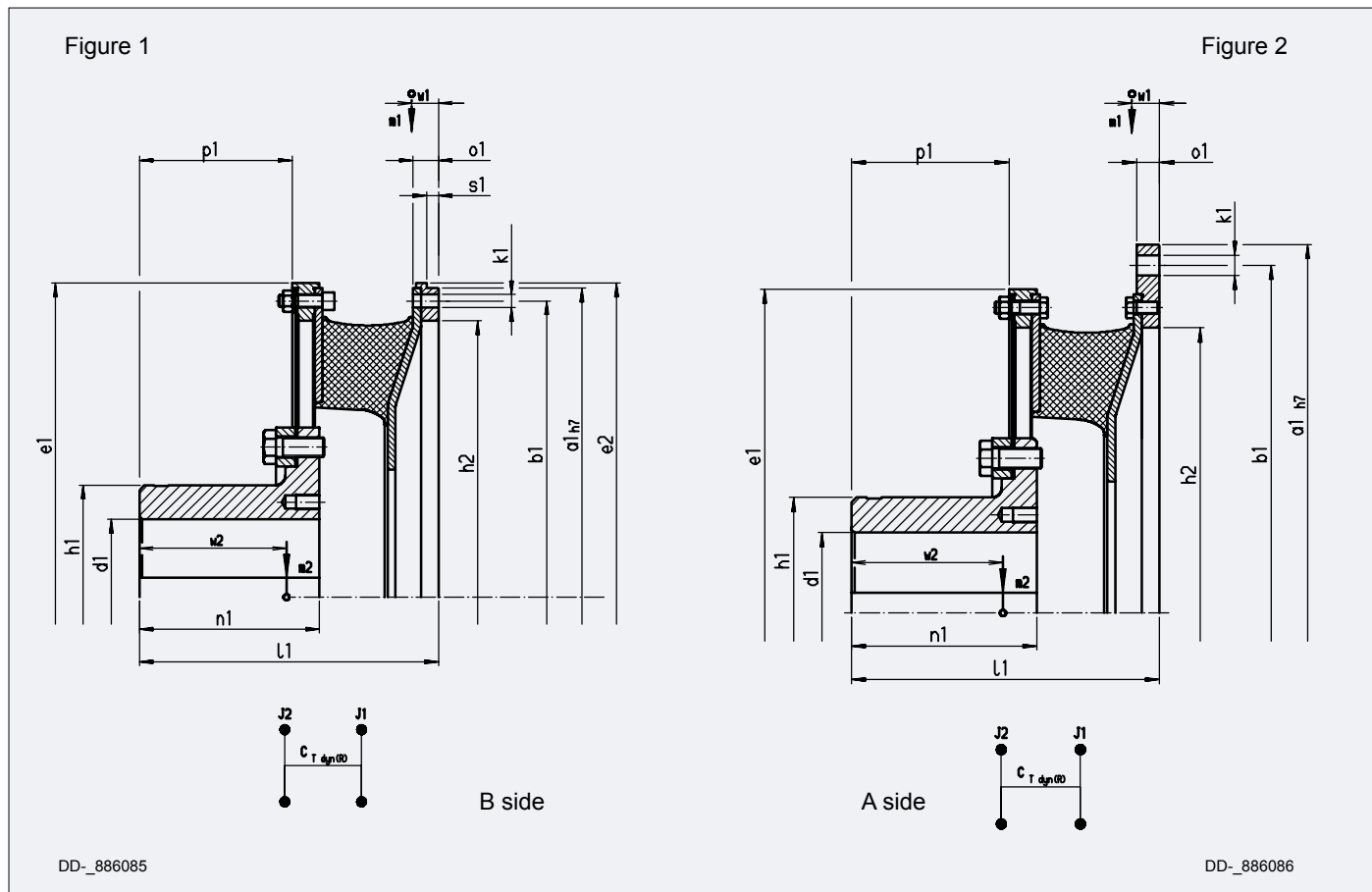

Coupling size		84	94	104	114	124
Flywheel Connection to SAE J620		metr.	24"	metr.	metr.	metr.
Figure		1	1	1	1	1
Diameter mm	$d_{1\text{ vor}}$	90	90	100	110	120
	$d_{1\text{ max}}$	185	185	200	220	235
	$a_1$	730	733.4	790	860	920
	$b_1$	700	692.2	755	820	880
	$e_1$	740	740	804	875	935
	$e_2$	740	740	804	875	935
	$h_1$	260	260	280	308	330
	$h_2$	655	655	706	765	820
	$k_1$	32xØ15.5	12xØ20	32xØ17.5	32xØ20	32xØ21
Lengths mm	$l_1$	367	367	385	413	451
	$n_1$	225	225	235	250	275
	$p_1$	192	192	198	210	231
	$o_1$	30	30	32	33	37
	$s_1$	14	14	15	17	18
	$W_1$	43.5	43	46.5	49.5	58.0
	$W_2^*$	177	177	185	198	219
Masses kg	$m_1$	48.4	48.8	59.9	74.0	104.3
	$m_2^*$	121.8	121.8	153.0	203.4	252.9
Mass mom. of inertia kgm <sup>2</sup>	$J_1$	4.410	4.468	6.458	9.444	15.32
	$J_2^*$	6.131	6.131	9.213	14.56	21.24
*) at max. bore diameter. Other coupling sizes on request		Dimensions and construction subject to change				
**) + countersunk for cyl. screws ISO 4762						

# Stromag TRI-R Highly-Flexible Ring Coupling

## TEW..W – R Series

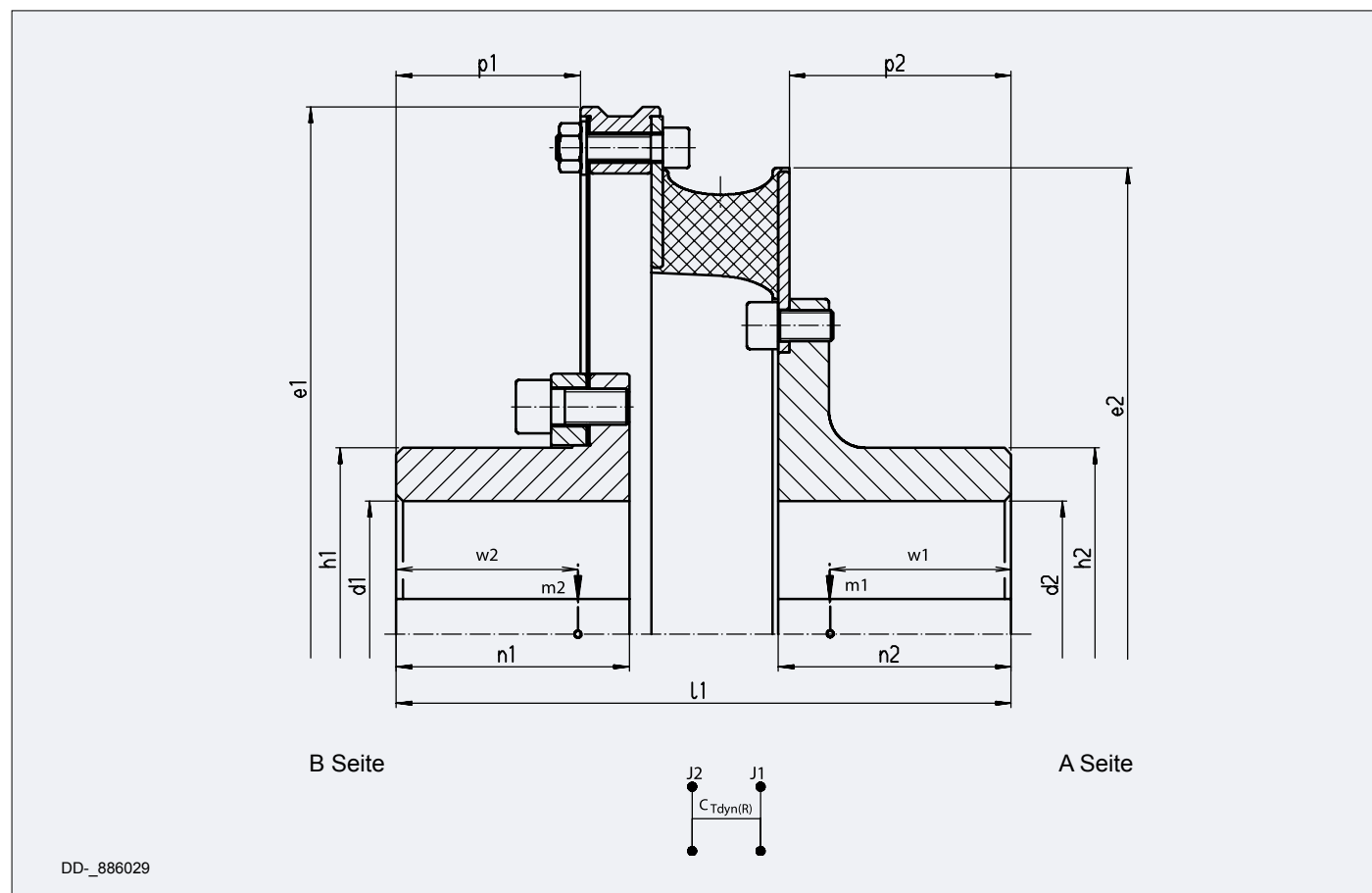

Coupling size		31	32	41	42	43	51	52
Diameter mm	$d_{1\text{ vor}}$	30	30	35	35	35	55	55
	$d_{1\text{ max}}$	85	85	120	120	120	150	150
	$d_{2\text{ vor}}$	30	30	35	35	35	55	55
	$d_{2\text{ max}}$	85	85	120	120	120	150	150
	$e_1$	360	360	475	475	475	608	608
	$e_2$	314	317	417	420	420	520	525
	$h_1$	120	120	168	168	168	210	210
	$h_2$	120	120	168	168	168	210	210
Lengths mm	$l_1$	272	272	277	277	277	432	432
	$n_1$	105	105	105	105	105	175	175
	$p_1$	105	105	105	105	105	175	175
	$o_1$	89	89	83	83	83	146.5	146.5
	$s_1$	101	101	100	100	100	169	169
	$W_1^*$	80	80.5	79.5	80.5	81	129.5	130.5
	$W_2^*$	87	87.5	87	87.5	88	142	141.5
	Masses kg	$m_1^*$	10.9	11	21.9	22.2	22.4	48.0
$m_2^*$		13.4	13.5	29.4	29.7	29.9	67.9	64.8
Mass mom. of inertia kgm <sup>2</sup>	$J_1^*$	0.082	0.086	0.306	0.317	0.326	0.968	1.022
	$J_2^*$	0.192	0.195	0.763	0.774	0.783	2.751	2.553
*) at max. bore diameter. Other coupling sizes on request				Dimensions and construction subject to change				

# Stromag TRI-R Highly-Flexible Ring Coupling

## TEW...W – R Series

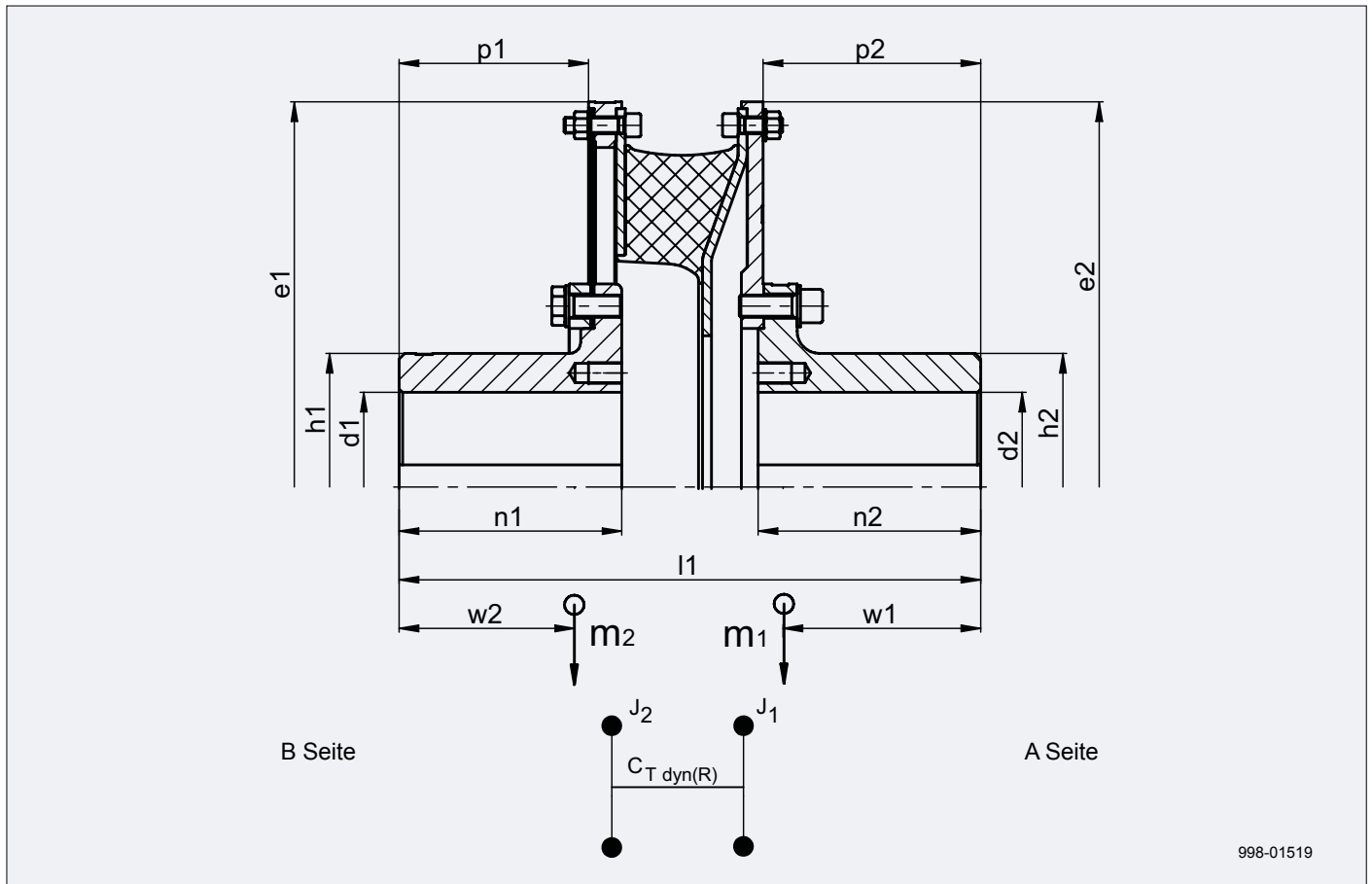

998-01519

Coupling size		64	74	84	94	104	114	124
Diameter mm	$d_{1 \text{ vor}}$	80	85	90	100	110	120	125
	$d_{1 \text{ max}}$	160	170	185	200	220	235	255
	$d_{2 \text{ vor}}$	80	85	90	100	110	120	125
	$d_{2 \text{ max}}$	160	170	185	200	220	235	255
	$e_1$	645	692	740	804	875	935	1010
	$e_2$	645	692	740	804	875	935	1010
	$h_1$	230	240	260	280	308	330	358
	$h_2$	230	240	260	280	308	330	358
Lengths mm	$l_1$	484	522,5	582	610	655	720	661
	$n_1$	185	200	225	235	250	275	315
	$n_2$	185	200	225	235	250	275	290
	$p_1$	157	170	192	198	210	231	167
	$p_2$	180,5	195,5	219,5	229,5	244,5	268,5	283,5
	$w_1^*$	163,5	177,5	199,5	209,5	223,5	249	255
	$w_2^*$	144	157,5	175	183	183	213,5	182,5
	Masses kg	$m_1^*$	97,4	120,8	151,7	190,3	253,7	330,1
$m_2^*$		82,6	99,4	123,9	156,6	207,6	248,9	324,1
Mass mom. of inertia kgm <sup>2</sup>	$J_1^*$	3,929	5,534	8,074	12,057	19,023	28,99	37,74
	$J_2^*$	3,246	4,617	6,337	9,614	15,344	20,641	30,545
*) at max. bore diameter. Other coupling sizes on request				Dimensions and construction subject to change				

# Stromag TRI-R Highly-Flexible Ring Coupling

## TEF...W – RR Series

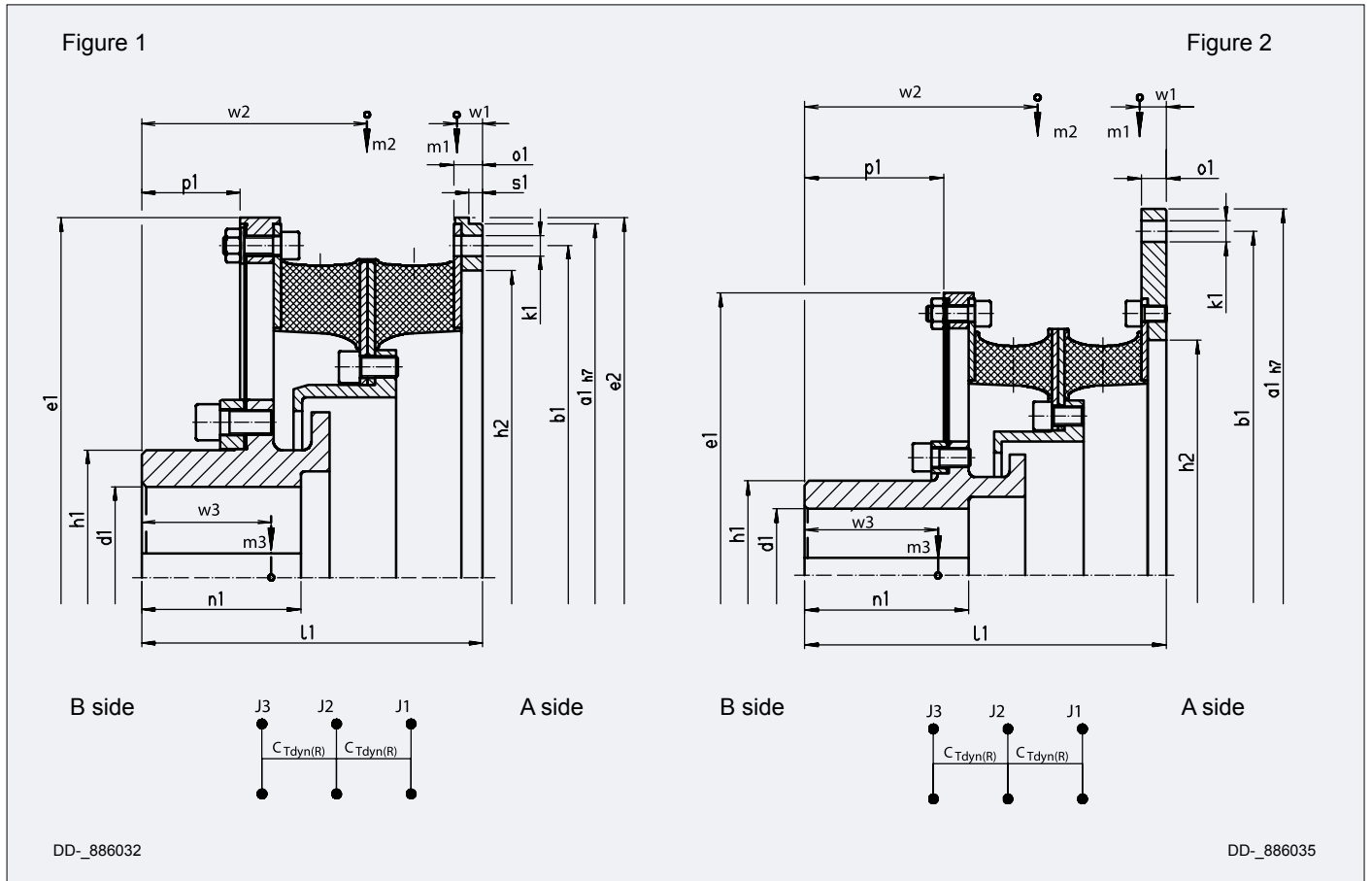

DD\_-886032

DD\_-886035

Coupling size		31		32		41		42		
Flywheel Connection to SAE J620		11,5"	14"	11,5"	14"	14"	16"	14"	16"	18"
Figure		1	2	1	2	1	2	1	2	2
Diameter mm	$d_{1\text{ vor}}$	30	30	30	30	35	35	35	35	35
	$d_{1\text{ max}}$	85	85	85	85	120	120	120	120	120
	$a_1$	352.4	466.7	352.4	466.7	466.7	517.5	466.7	517.5	571.5
	$b_1$	333.4	438.2	333.4	438.2	438.2	489	438.2	489	542.9
	$e_1$	360	360	360	360	475	475	475	475	475
	$e_2$	360	-	360	-	475	-	475	-	-
	$h_1$	120	120	120	120	168	168	168	168	168
	$h_2$	300	300	300	300	405	405	405	405	405
Lengths mm	$k_1$	8xØ11	8xØ13.5	8xØ11	8xØ13.5	8xØ13.5	8xØ13.5	8xØ13.5	8xØ13.5	12xØ17.5
	$l_1$	231	231	231	231	225	225	225	225	225
	$n_1$	105	105	105	105	105	105	105	105	105
	$p_1$	89	89	89	89	65	65	65	65	65
	$o_1$	16	16	16	16	19	18	19	18	18
	$s_1$	8	-	8	-	9	-	9	-	-
	$W_1$	13.5	10	19.5	10.5	15.5	13	16.5	13.5	12.5
	$W_2$	160	160	160.5	160.5	147	147	147	147	147
$W_3^*$	88.5	88.5	89	89	74.5	74.5	75	75	75	
Masses kg	$m_1$	5.1	14	5.2	14.2	9.7	14.8	10	15.1	21.6
	$m_2$	7.6	7.6	7.9	7.9	14.9	14.9	15.5	15.5	15.5
	$m_3^*$	14	14	14.1	14.1	29.3	29.3	29.6	29.6	29.6
Mass mom. of inertia kgm <sup>2</sup>	$J_1$	0.126	0.512	0.129	0.516	0.424	0.734	0.435	0.745	1.230
	$J_2$	0.106	0.106	0.114	0.114	0.374	0.374	0.395	0.395	0.395
	$J_3^*$	0.167	0.167	0.171	0.171	0.661	0.661	0.672	0.672	0.672
*) at max. bore diameter. Other coupling sizes on request						Dimensions and construction subject to change				



# Stromag TRI-R Highly-Flexible Ring Coupling

## TEF..W – RR Series

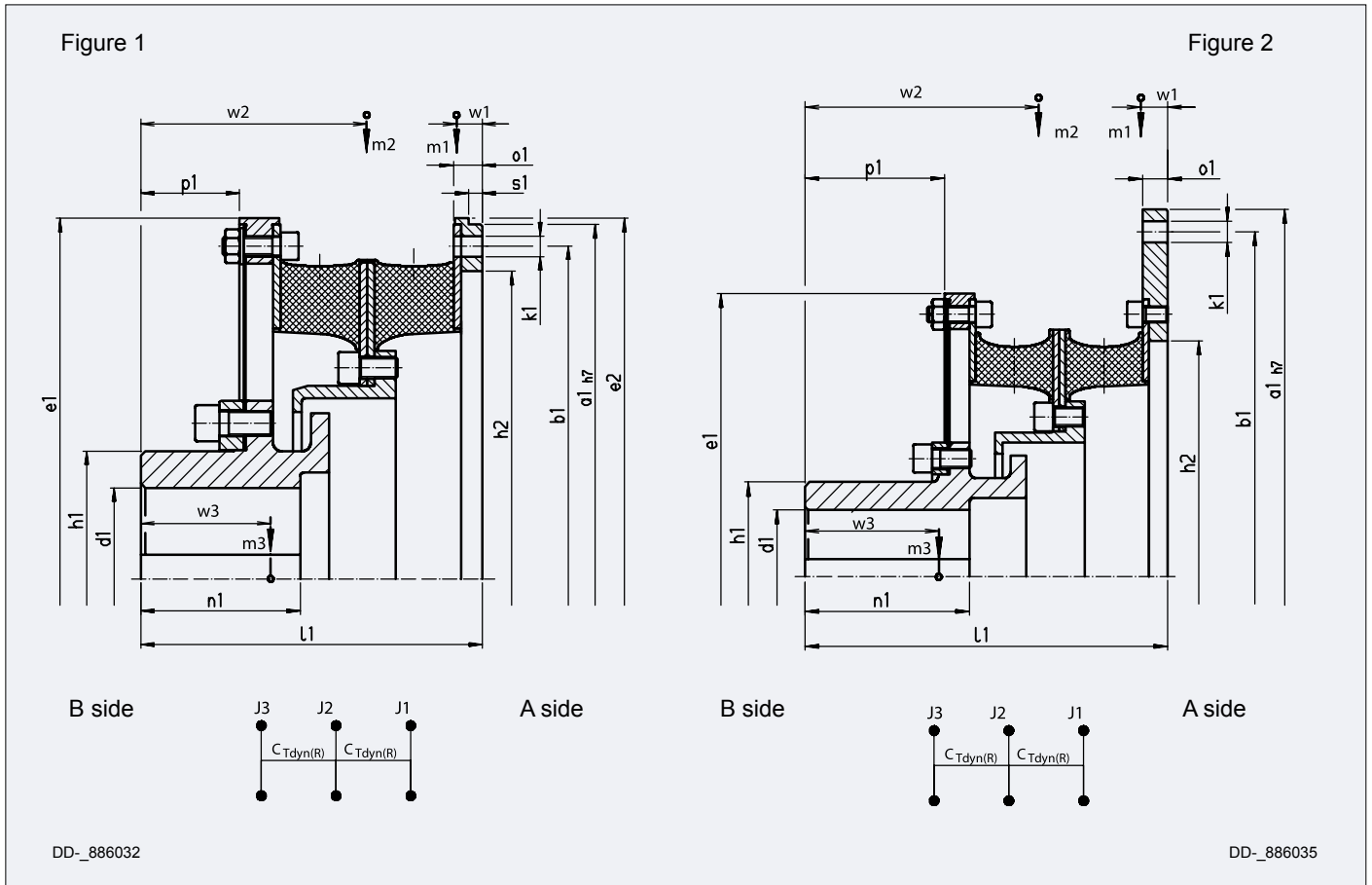

Coupling size		43			51		52		
Flywheel Connection to SAE J620		14"	16"	18"	18"	21"	18"	21"	24"
Figure		1	2	2	1	2	1	1	2
Diameter mm	$d_{1\text{ vor}}$	35	35	35	55	55	55	55	55
	$d_{1\text{ max}}$	120	120	120	150	150	150	150	150
	$a_1$	466.7	517.5	571.5	571.5	673.1	571.5	673.1	733.4
	$b_1$	438.2	489	542.9	542.9	641.4	542.9	641.4	692.2
	$e_1$	475	475	475	608	608	608	608	608
	$e_2$	475	-	-	580	-	608	683	-
	$h_1$	168	168	168	210	210	210	210	210
	$h_2$	405	405	405	505	514	505	600	542
Lengths mm	$k_1$	8xØ13.5	8xØ13.5	12xØ17.5	12xØ17.5	12xØ17.5	12xØ17.5**	12xØ17.5	12xØ20
	$l_1$	225	225	225	289	291	287	272	274
	$n_1$	105	105	105	175	175	175	175	175
	$p_1$	65	65	65	77.5	77.5	77.5	77.5	77.5
	$o_1$	19	18	18	24	25	15.5	24	25
	$s_1$	9	-	-	10	-	8	10	-
	$w_1$	17	14	12.5	22	18	29.5	15	17.5
	$w_2$	147	147	147	192.5	192.5	177.5	177.5	177.5
Masses kg	$w_3$	75	75	75	98.5	98.5	95	95	95
	$m_1$	10.2	15.3	21.8	18.5	36.9	32	26.7	47.4
	$m_2$	15.9	15.9	15.9	29.7	29.7	29.9	29.9	29.9
Mass mom. of inertia kgm <sup>2</sup>	$m_3$	29.8	29.8	29.8	70	70	60.2	60.2	60.2
	$J_1$	0.442	0.754	1.239	1.191	3.016	2.257	2.242	4.452
	$J_2$	0.414	0.414	0.414	1.148	1.148	1.227	1.227	1.227
	$J_3$	0.681	0.681	0.681	2.777	2.777	2.052	2.052	2.052
*) at max. bore diameter. Other coupling sizes on request					Dimensions and construction subject to change				
**) + countersunk for cyl. screws ISO 4762									

# Stromag TRI-R Highly-Flexible Ring Coupling

## TEF...W – RR Series

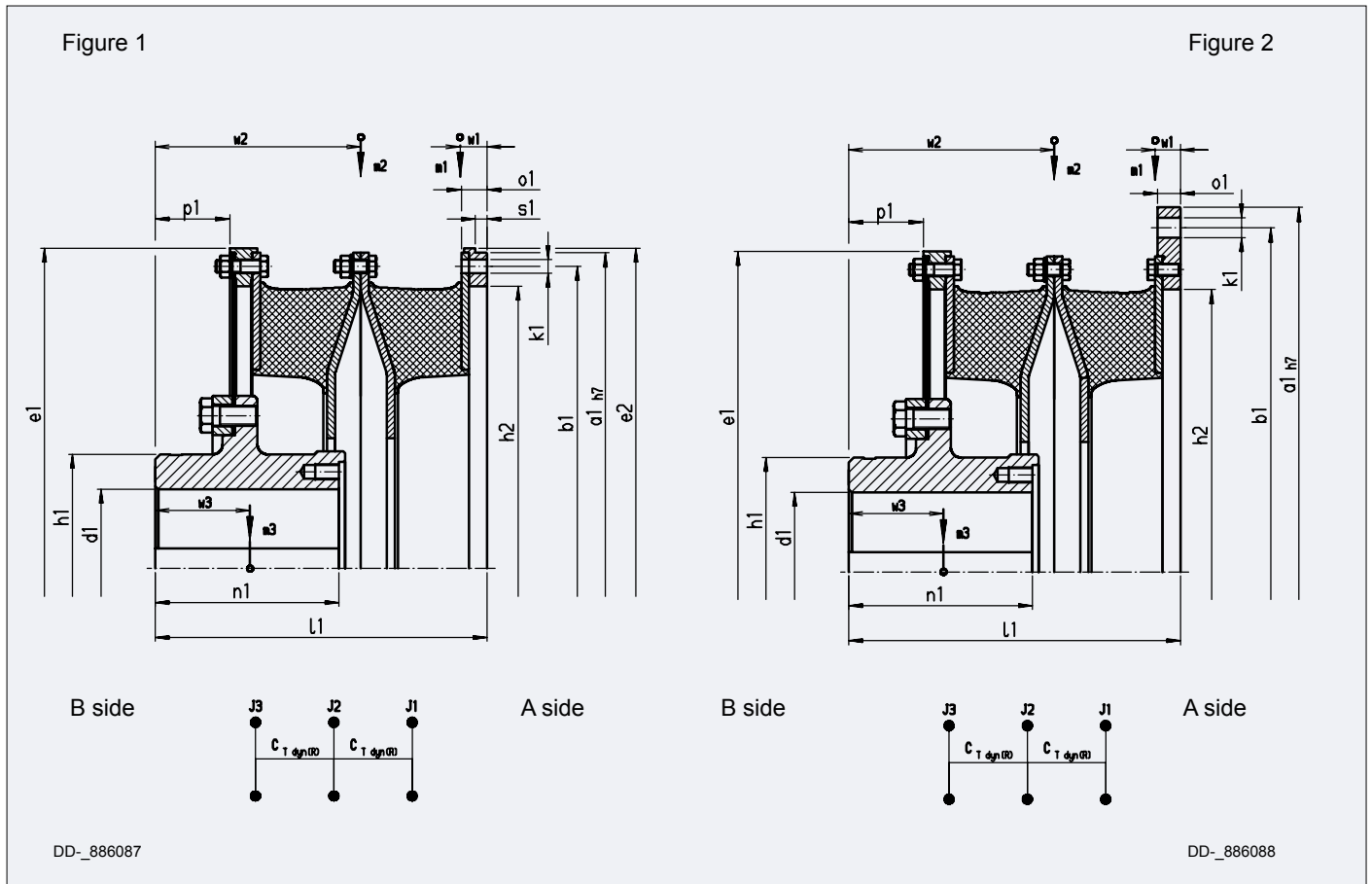

Coupling size		64				74		
Flywheel Connection to SAE J620		metr.	18"	21"	24"	metr.	21"	24"
Figure		1	2	2	2	1	1	2
Diameter mm	$d_{1\text{vor}}$	80	80	80	80	85	85	85
	$d_{1\text{max}}$	160	160	160	160	170	170	170
	$a_1$	635	571.5	673.1	733.4	680	673.1	733.4
	$b_1$	608	542.9	641.4	692.2	650	641.4	692.2
	$e_1$	645	645	645	645	692	692	692
	$e_2$	645	645	-	-	692	692	-
	$h_1$	230	230	230	230	240	240	240
	$h_2$	568	490	568	568	610	600	610
Lengths mm	$k_1$	32xØ13.5	12xØ17.5	12xØ17.5	12xØ20	32xØ15.5	12xØ17.5	12xØ20
	$l_1$	334	342	342	334	359	359	369
	$n_1$	185	185	185	185	200	200	200
	$p_1$	75	75	75	75	80	80	80
	$o_1$	26	15**	8.5**	23	28	28	10.5**
	$s_1$	12	8	-	-	12	12	-
	$W_1$	27.5	28.5	28	25.5	30	40	30
	$W_2$	207	207	207	207	222	212.5	222
$W_3^*$	95.5	95.5	95.5	95.5	103	103	103	
Masses kg	$m_1$	28.3	41.3	42.3	34.3	34.9	41.2	55.4
	$m_2$	46.8	46.8	46.8	46.8	55.8	50.3	55.8
	$m_3^*$	82.8	82.8	82.8	82.8	99.2	99.2	99.2
Mass mom. of inertia kgm <sup>2</sup>	$J_1$	2.123	3.039	3.566	3.124	2.952	3.228	5.444
	$J_2$	2.750	2.750	2.750	2.750	3.707	3.519	3.707
	$J_3^*$	3.178	3.178	3.178	3.178	4.453	4.453	4.453
*) at max. bore diameter. Other coupling sizes on request					Dimensions and construction subject to change			
**) + countersunk for cyl. screws ISO 4762								

# Stromag TRI-R Highly-Flexible Ring Coupling

## TEF..W – RR Series

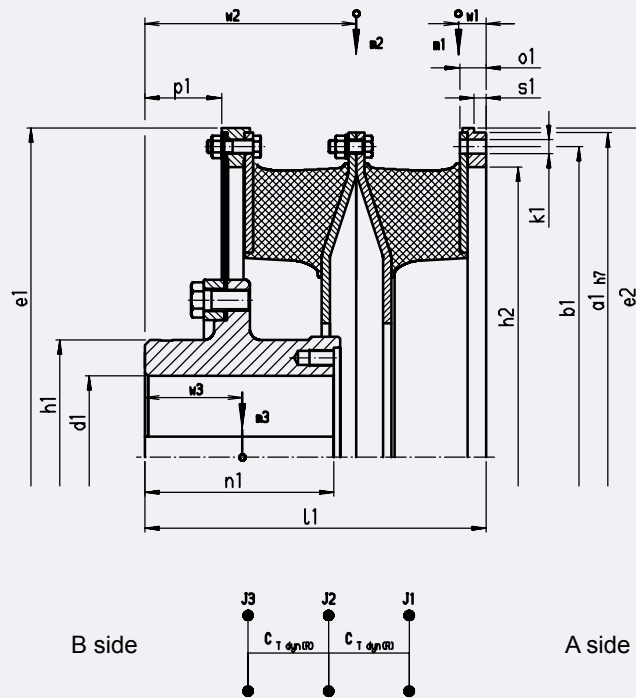

DD\_886087

Coupling size		84		94	104	114	124
Flywheel Connection to SAE J620		metr.	24"	metr.	metr.	metr.	metr.
Figure		1	1	1	1	1	1
Diameter mm	$d_{1 \text{ vor}}$	90	90	100	110	120	125
	$d_{1 \text{ max}}$	185	185	200	220	235	255
	$a_1$	730	733.4	790	860	920	995
	$b_1$	700	692.2	755	820	880	950
	$e_1$	740	740	804	875	935	1010
	$e_2$	740	740	804	875	935	-
	$h_1$	260	260	280	308	330	358
	$h_2$	655	655	706	765	820	905
	$k_1$	32xØ15.5	12xØ20	32xØ17.5	32xØ20	32xØ20	32xØ21
Lengths mm	$l_1$	396	396	419	457	492	417
	$n_1$	225	225	235	250	275	315
	$p_1$	95	95	98	106	112	73
	$o_1$	30	30	32	35	37	12
	$s_1$	14	14	15	17	18	12
	$W_1$	33	43	35	37.5	45	33
	$W_2$	248	238	261	284	305	265
	$W_3^*$	118.5	118.5	123	132	144.5	127
Masses kg	$m_1$	42.0	48.8	52.8	71.2	92.3	84.0
	$m_2$	66.2	59.9	78.7	96.3	145.5	187.0
	$m_3^*$	125.1	125.1	156.2	207.2	257.9	318.0
Mass mom. of inertia kgm <sup>2</sup>	$J_1$	4.141	4.468	6.129	9.697	14.56	11.94
	$J_2^*$	5.114	4.845	7.086	10.22	18.53	24.79
	$J_3^*$	6.192	6.192	9.280	14.75	21.38	28.67

\*) at max. bore diameter. Other coupling sizes on request

\*\*) + countersunk for cyl. screws ISO 4762

Dimensions and construction subject to change

# Stromag TRI-R Highly-Flexible Ring Coupling

## TEW..W – RR Series

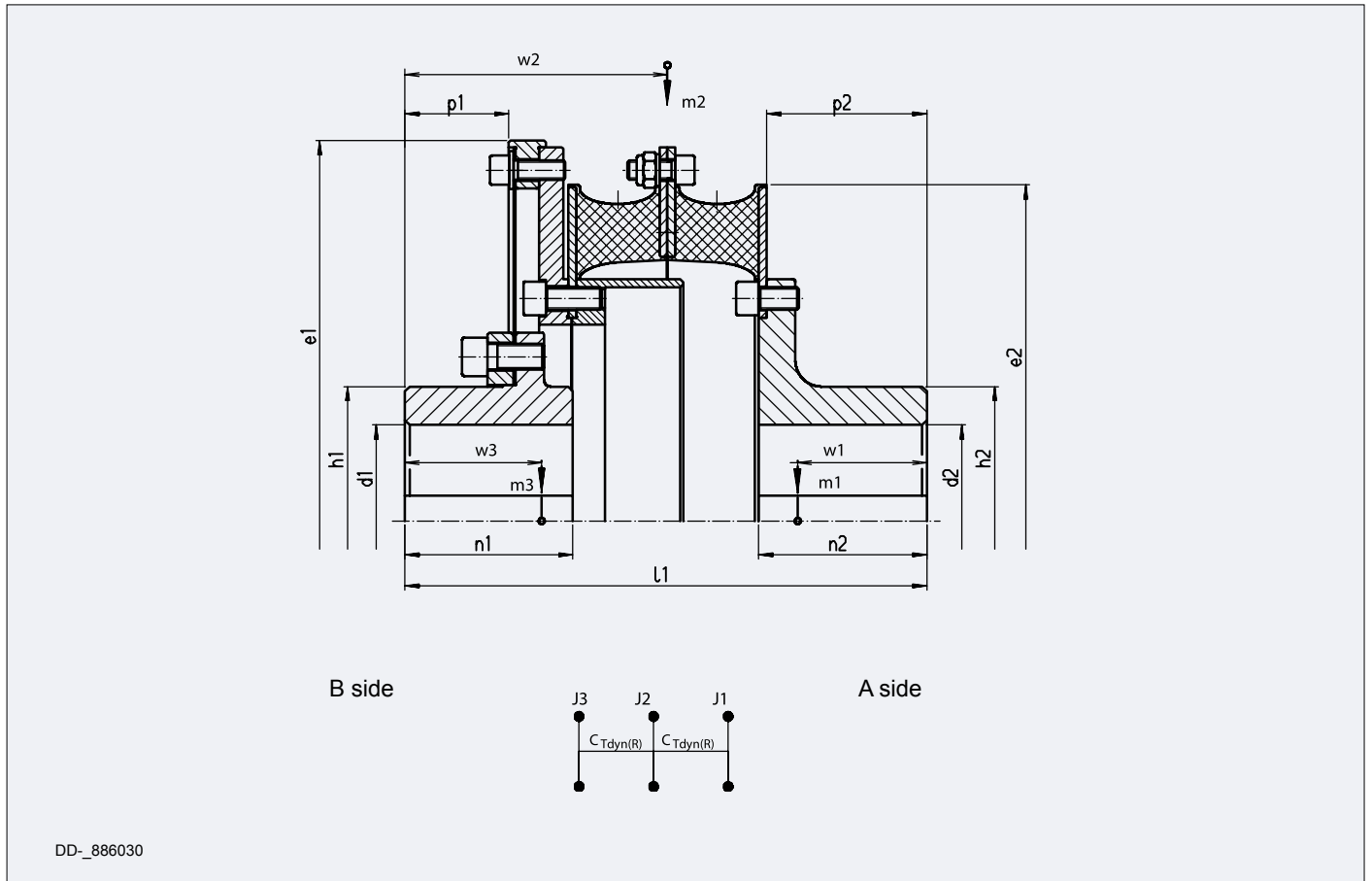

Coupling size		31	32	41	42	43	51	52
Diameter mm	$d_{1\text{ vor}}$	30	30	35	35	35	55	55
	$d_{1\text{ max}}$	85	85	120	120	120	150	150
	$d_{2\text{ vor}}$	30	30	35	35	35	55	55
	$d_{2\text{ max}}$	85	85	120	120	120	150	150
	$e_1$	360	360	475	475	475	608	608
	$e_2$	314	317	417	420	420	520	525
	$h_1$	120	120	168	168	168	210	210
	$h_2$	120	120	168	168	168	210	210
Lengths mm	$l_1$	287	287	326	326	326	450	450
	$n_1$	105	105	105	105	105	175	175
	$p_1$	105	105	105	105	105	175	175
	$o_1$	77	77	65	65	65	82.5	82.5
	$s_1$	68	68	100	100	100	169	169
	$W_1^*$	61.5	62	79.5	80.5	81	129.5	131
	$W_2^*$	162	162	164	164	164	204	204
	$W_3^*$	90.5	90.5	85	85.5	85.5	109	109.5
	Masses kg	$m_1^*$	11.0	11.2	21.9	22.2	22.4	48.0
$m_2^*$		4.6	4.9	9.2	9.8	10.2	19.5	23.4
$m_3^*$		21.9	22.0	46.4	46.7	46.9	98.1	98.9
Mass mom. of inertia kgm <sup>2</sup>	$J_1^*$	0.083	0.087	0.306	0.317	0.326	0.968	1.023
	$J_2^*$	0.099	0.106	0.352	0.373	0.392	1.097	1.402
	$J_3^*$	0.304	0.308	1.180	1.191	1.200	3.785	3.840

\*) at max. bore diameter. Other coupling sizes on request

Dimensions and construction subject to change

# Stromag TRI-R Highly-Flexible Ring Coupling

## TEW...W – RR Series

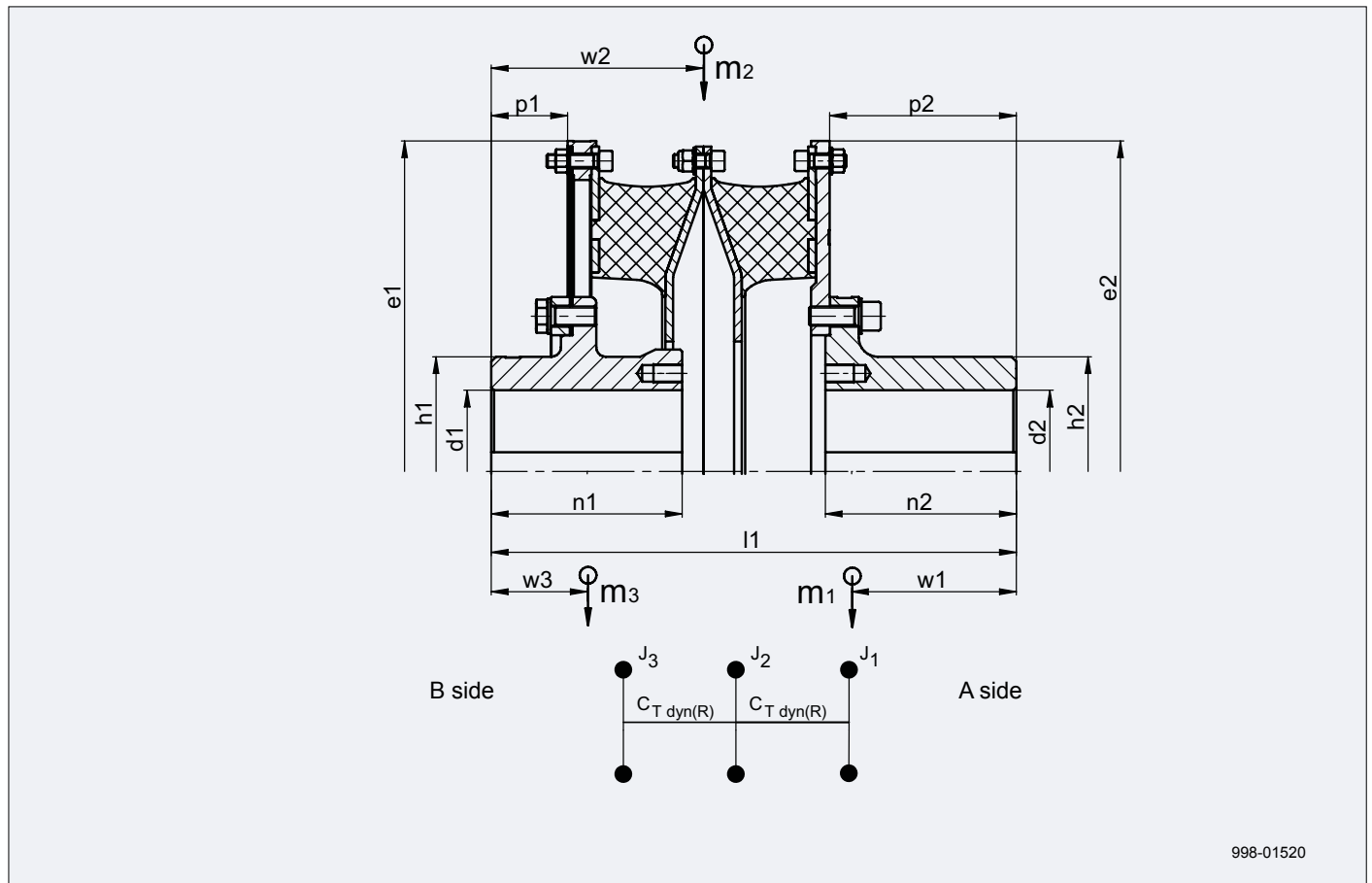

Coupling size		64	74	84	94	104	114	124
Diameter mm	$d_{1 \text{ vor}}$	80	85	90	100	110	120	125
	$d_{1 \text{ max}}$	160	170	185	200	220	235	255
	$d_{2 \text{ vor}}$	80	85	90	100	110	120	125
	$d_{2 \text{ max}}$	160	170	185	200	220	235	255
	$e_1$	645	692	740	804	875	935	1010
	$e_2$	645	692	740	804	875	935	1010
	$h_1$	230	240	260	280	308	330	358
	$h_2$	230	240	260	280	308	330	358
Lengths mm	$l_1$	511	550	611	644	699	761	723
	$n_1$	185	200	225	235	250	275	315
	$n_2$	185	200	225	235	250	275	290
	$p_1$	75	80	95	98	106	112	73
	$p_2$	180.5	195.5	219.5	229.5	244.5	268.5	283.5
	$w_1^*$	158	172.5	193	203.5	225	242	255
	$w_2$	207	222	248	260.5	283.5	304.5	265
	$w_3^*$	93	100.5	116	119.5	128	139	123
Masses kg	$m_1^*$	91.4	114.5	144.6	181.4	248.3	315.3	383
	$m_2$	48.9	60.2	69.4	83.4	103.5	140	193.7
	$m_3^*$	83.6	100.8	126.7	160.2	211.2	254.4	322
Mass mom. of inertia kgm <sup>2</sup>	$J_1^*$	3.712	5.297	7.702	11.528	18.944	27.814	37.74
	$J_2$	2.942	4.171	5.518	7.864	11.438	17.671	26.523
	$J_3^*$	3.259	4.594	6.394	9.687	15.435	20.801	29.976

\*) at max. bore diameter. Other coupling sizes on request

Dimensions and construction subject to change

# Stromag TRI-R Highly-Flexible Ring Coupling

## Characteristics of the Stromag TRI-R coupling

<b><math>T_{KN}</math></b>	
The coupling's nominal torque can be permanently transferred over the whole permitted speed range. It must be higher than the system's nominal torque $T_N$ .	$T_{KN} \geq T_N$
<b><math>T_{Kmax1}</math></b>	
The coupling's max torque $T_{Kmax1}$ can be endured as a peak load and may not be exceeded by peak torques $T_{max1}$ when the system is operating in normal, nonstationary mode. A system's normal nonstationary modes are unavoidable and occur repeatedly (e.g. starting/stopping, resonance passes, switchovers, accelerations, etc.).	$T_{Kmax1} \geq T_{max1}$
<b><math>T_{Kmax2}</math></b>	
The coupling's max torque $T_{Kmax2}$ can be endured as a peak load and may not be exceeded by peak torques $T_{max2}$ when the system is operating in anomalous, nonstationary mode. A system's anomalous, nonstationary modes are avoidable and are not part of the planned operating scheme (e.g. emergency stops, sync failure, short circuits, etc.) Overloading the Stromag TRI-R coupling with peak torques $T_{max2}$ in a system's anomalous nonstationary mode shortens the service life and is tolerated in individual cases.	$T_{Kmax2} \geq T_{max2}$
<b><math>T_{Kw}</math></b>	
The admissible permanent alternating torque describes the amplitude of the max permanent periodic torque variation. This torque may be superimposed on a base load equal to $T_{KN}$ . This requires in addition an analysis of the max damping power $P_{KV}$ .	
<b><math>\Delta K_a</math></b>	
Max axial displacement of the coupling. The shaft's axial displacement $\Delta W_a$ must be less than $\Delta K_a$ .	$\Delta K_a \geq \Delta W_a$
<b><math>\Delta K_r</math></b>	
Max radial displacement of the coupling. The shaft's radial displacement $\Delta W_r$ must be less than $\Delta K_r$ .	$\Delta K_r \geq \Delta W_r$
The values of $\Delta K_r$ for the Stromag TRI-R coupling refer to coupling shaft speeds up to 600 rpm. The conversion to other speeds is made by the equation	$\Delta K_r(n) = \sqrt{\frac{600 \text{ min}^{-1}}{n}} \cdot \Delta K_r$
With ambient temperatures higher than 30°C, the admissible radial offset must be reduced by the temperature factor $S_{gKr}$ .	$\Delta K_r(T_U) = \frac{\Delta K_r}{S_{gKr}}$
<b><math>\Delta K_w</math></b>	
Max angular displacement of the coupling. The shaft's angular displacement $\Delta W_w$ must be less than $\Delta K_w$ . A $\Delta K_w$ value of 0.5° is permitted for TRI-R couplings. This value, however, may be utilised to the full only when there are no other options for shaft displacement.	$\Delta K_w \geq \Delta W_w$

# Stromag TRI-R Highly-Flexible Ring Coupling

## Characteristics of the Stromag TRI-R coupling

<b>F<sub>a</sub></b>	
The axial reaction force of the diaphragm is stated for an offset of 1 mm. Steel diaphragms have a progressive characteristic. Formulas for the calculation of larger axial offsets on request.	
<b>C<sub>r</sub></b>	
The radial stiffness represents the ratio of radial reaction force to radial displacement. The specified values apply to the coupling at operating temperature, with a surface temperature of about 30°C.	
<b>C<sub>Tdyn</sub></b>	
<p>The dynamic torsional spring stiffness represents the ratio of torque amplitude to torque angle during an oscillation.</p> <p>The torque amplitude is superimposed on an initial load (coupling torque). Stromag TRI-R coupling's C<sub>Tdyn</sub> value remains constant over the coupling torque (linear characteristic curve), but changes with the amplitude, frequency, and temperature of the flexible element.</p> <p>The specified nominal values for C<sub>Tdyn</sub> are based on a coupling torque of 0.8 • T<sub>KN</sub>, an alternating torque of 0.2 • T<sub>KN</sub>, and a frequency of 10 Hz on a coupling at operating temperature, with a surface temperature of about 30°C.</p>	$C_{Tdyn} = \frac{T_{el}}{\varphi_w}$
<b>C<sub>Tdyn warm</sub></b> takes into account that high power dissipation causes the coupling to heat up.	$C_{Tdyn\ warm} = 0,7 \cdot C_{Tdyn}$
<b>C<sub>Tdyn A</sub></b> takes into account the effects of a small alternating torque amplitude.	$C_{Tdyn\ A} = 1,35 \cdot C_{Tdyn}$
Calculations of torsional vibrations in the system are recommended to include C <sub>Tdyn warm</sub> (0,7), und C <sub>Tdyn A</sub> (1,35)	

<b>Ψ</b>	
<p>The relative damping is a factor for the capacity of a coupling to convert a part of the occurring cyclic energy into heat.</p> <p>The damping can be determined by the damping loop (hysteresis loop).</p> <p>The area A<sub>D</sub> is a factor for the damping work W<sub>D</sub> during a vibration cycle.</p> <p>The area A<sub>el</sub> represents the work done in deflection W<sub>el</sub> at a given load.</p> <p>The specified nominal values for Ψ are based on a coupling torque of 0.8 • T<sub>KN</sub>, an alternating torque of 0.2 • T<sub>KN</sub>, and a frequency of 10 Hz on a coupling at operating temperature, with a surface temperature of about 30°C.</p>	$\Psi = \frac{W_D}{W_{el}} = \frac{A_D}{A_{el}}$

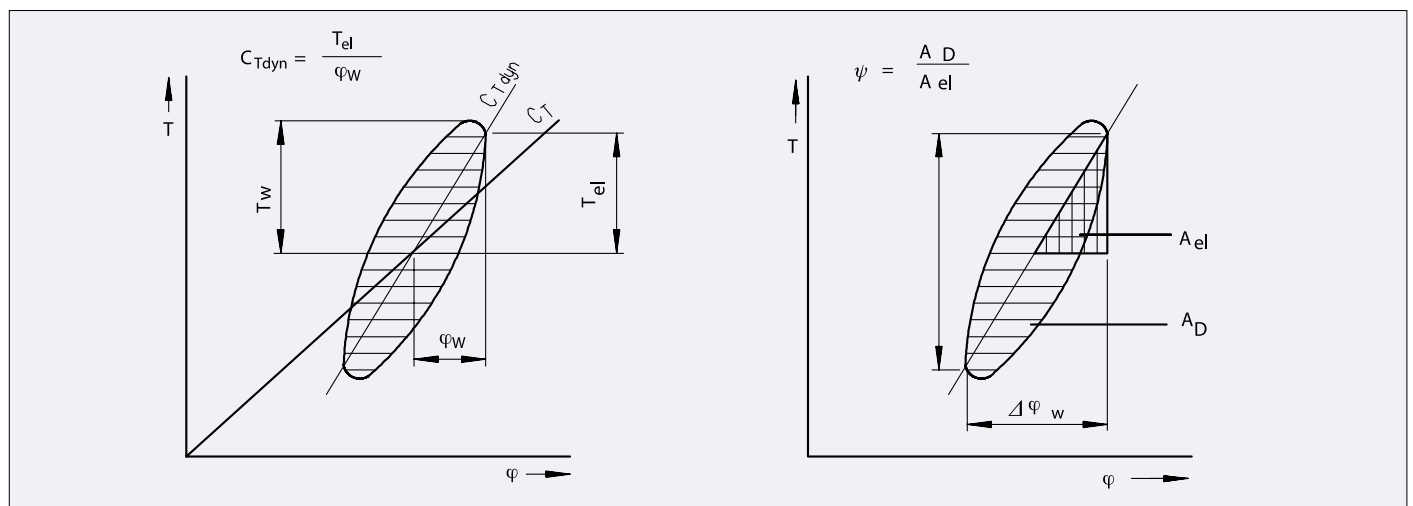

# Stromag TRI-R Highly-Flexible Ring Coupling

## Characteristics of the Stromag TRI-R coupling

### $P_{kv}$

The admissible damping power indicates how much damping (heat) the coupling can permanently absorb resp. dissipate. The sum of the damping power of each vibration order (i.e.  $\Sigma P_{vi}$ ) must be less than the damping power of the coupling.

$$P_{vi} = \frac{\pi}{\sqrt{\left(\frac{2\pi}{\Psi}\right)^2 + 1}} \cdot \frac{T_{wi}^2 \cdot f_i}{C_{tdyn}}$$

$$P_{kv} \geq \Sigma P_{vi}$$

The stated value  $P_{kv60}$  describes the damping power which can be absorbed over the period of 1 hour. To determine the damping power which can be permanently absorbed ( $P_{kv\infty}$ ), the value  $P_{kv60}$  has to be multiplied by the factor 0.5. With an ambient temperature  $T_U$  higher than 30°C, the admissible damping power must be reduced by the temperature factor  $S_{9PKV}$ .

$$P_{kv}(T_U) = \frac{P_{kv}}{S_{9PKV}}$$

### Temperature factors $S_{Kr}$ and $S_{9PKV}$

Temperature factors shall take into consideration the reduction of the physical characteristics of rubber-flexible material caused by heating.

The coupling temperature is determined by the ambient temperature plus an internal heating caused by internal material friction in the rubber volume, resulting from alternating torques and alternating loads due to shaft offsets.

With higher ambient temperatures the coupling characteristic values  $\Delta_{Kr}$  and  $P_{kv}$  must be reduced through the corresponding temperature factors  $S_{9Kr}$  and  $S_{9PKV}$ .

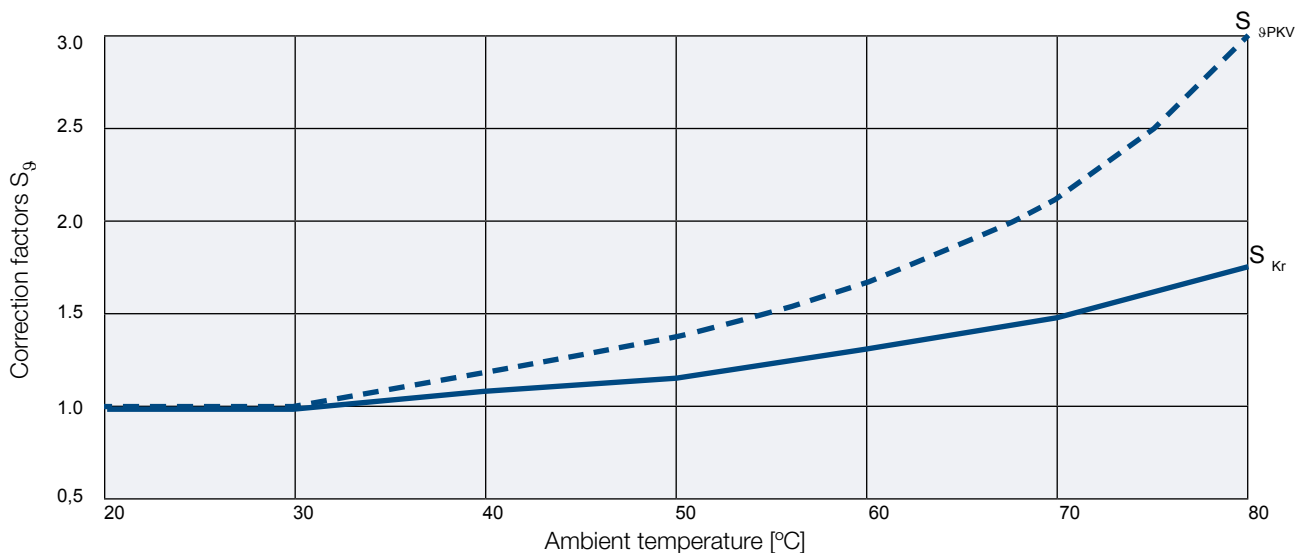



# Stromag TRI-R Highly-Flexible Ring Coupling

## Coupling design, question sheet

Driving machine		
Engine system (electric motor, combustion engine etc.)		
Engine type (make, type)		
Engine mounting (rigid or resilient)		
SAE housing of engine		
Flywheel centering diameter		mm
Nominal output		kW
Nominal speed		rpm
Speed range		rpm
Nominal torque		Nm
Max. torque (max. breakdown torque)		Nm
Mass moment of inertia		kgm <sup>2</sup>
Number of starts resp. reversing processes per hour		
Gear		
Reduction		
Mass moment of inertia		kgm <sup>2</sup>
Driving machine		
System (generator, fan, compressor, fixed- or controllable pitch propeller)		
Main or auxiliary drive		
Type of construction (self-supporting or flange-type connected)		
Mass moment of inertia		kgm <sup>2</sup>
Coupling		
Assembly site in the driving line (provide a principle sketch)		
Bore dimensions for the coupling hub		mm
Ambient temperature		°C, °K
Classification society		
Type of vessel		
Ice class		

# Stromag TRI-R Highly-Flexible Ring Coupling

## Use in potentially explosive environments, question sheet

Applications		<input type="radio"/>	Group II (above ground)
Potentially explosive atmosphere of air and		<input type="radio"/>	gas
		<input type="radio"/>	dust
Zone (Category)	gas	<input type="radio"/>	zone 1 (Category 2G)
		<input type="radio"/>	zone 2 (Category 3G)
	dust	<input type="radio"/>	zone 22 not electrically conducting (Category 3D)
Temperature category in atmosphere with gas	gas	<input type="radio"/>	T1
		<input type="radio"/>	T2
		<input type="radio"/>	T3
		<input type="radio"/>	T4
Max surface temperature	dust	<input type="radio"/>	125°C
		<input type="radio"/>	< 120°C
		<input type="radio"/>	-20°C to +40°C
Ambient temperature		<input type="radio"/>	other ambient temperatures only with certain restrictions

# Stromag TRI-R Highly-Flexible Ring Coupling

## Special designs

### TEF..W – RR / MWU

2 in 1 combination with an electric pole-face friction clutch to connect two machines from shaft to shaft.

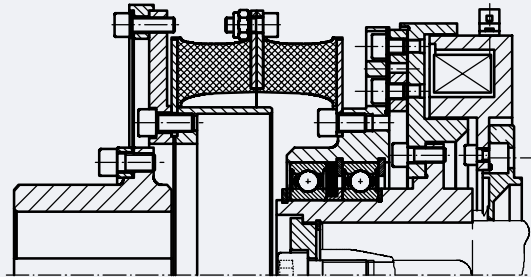

DD-\_886282

### TEF..W – RRDP

For mounting to a propeller shaft of a marine drive, additionally to absorb axial thrust.

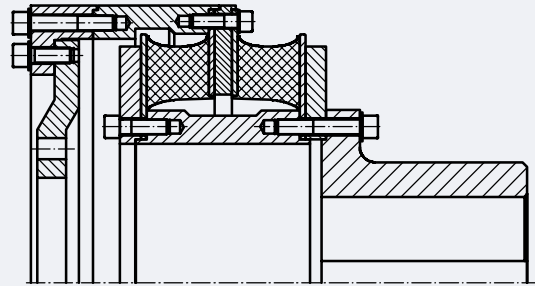

DD-\_886281

### TEF..W – 3R

To connect a flywheel or equivalent to a shaft.  
Low torsional stiffness due to 3 ring elements in series.

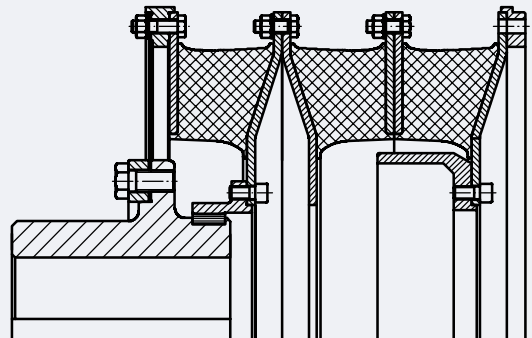

DD-\_886280

## Stromag Facilities

### Europe

#### Germany

Hansastraße 120  
59425 Unna - Germany  
+49 (0) 23 03 102 0

*Clutches & Brakes, Couplings,  
Geared Cam Limit Switches, Discs,  
Wind Brakes*

Dessauer Str. 10  
06844 Dessau-Roßlau - Germany  
+49 (0) 340 2190 0

*Electromagnetic Clutches & Brakes*

#### France

Avenue de l'Europe  
18150 La Guerche sur L'Aubois - France  
+33 (0)2 48 80 72 72

*Disc Brakes & Drum Brakes*

#### Great Britain

Amphill Road  
Bedford, MK42 9RD - UK  
+44 (0)1234 350311

*Electromagnetic Clutches & Brakes,  
Industrial Caliper Brakes*

### North America

#### USA

31 Industrial Park Road  
New Hartford, CT 06057 - USA  
860-238-4783

*Electromagnetic Clutches & Brakes*

300 Indiana Highway 212  
Michigan City, IN 46360 - USA  
219-874-5248

*Couplings*

2800 Fisher Rd.  
Wichita Falls, TX  
940-723-3400

*Geared Cam Limit Switches,  
Industrial Caliper & Drum Brakes*

### Asia Pacific

#### China

T40B -5, No. 1765 Chuan Qiao Road  
Pudong 201206, Shanghai - China  
Tel +86 21-60580600

*Clutches & Brakes, Electromagnetic  
Clutches & Brakes, Couplings, Industrial  
Caliper & Drum Brakes, Discs, Geared  
Cam Limit Switches, Wind Brakes*

#### India

Gat No.: 448/14, Shinde Vasti, Nighoje  
Tal Khed, Pune- 410 501  
+91 2135 622100

*Clutches & Brakes, Electromagnetic  
Clutches & Brakes, Couplings, Industrial  
Caliper & Drum Brakes, Discs, Geared  
Cam Limit Switches, Wind Brakes*

## The Brands of Altra Industrial Motion

### Couplings

**Ameridrives**  
www.ameridrives.com

**Bibby Turboflex**  
www.bibbyturboflex.com

**Guardian Couplings**  
www.guardiancouplings.com

**Huco**  
www.huco.com

**Lamiflex Couplings**  
www.lamiflexcouplings.com

**Stromag**  
www.stromag.com

**TB Wood's**  
www.tbwoods.com

### Geared Cam Limit Switches

**Stromag**  
www.stromag.com

### Electric Clutches & Brakes

**Inertia Dynamics**  
www.idicb.com

**Matrix**  
www.matrix-international.com

**Stromag**  
www.stromag.com

**Warner Electric**  
www.warnerelectric.com

### Linear Products

**Warner Linear**  
www.warnerlinear.com

### Engineered Bearing Assemblies

**Kilian**  
www.kilianbearings.com

### Heavy Duty Clutches & Brakes

**Industrial Clutch**  
www.indclutch.com

**Twiflex**  
www.twiflex.com

**Stromag**  
www.stromag.com

**Svendborg Brakes**  
www.svendborg-brakes.com

**Wichita Clutch**  
www.wichitaclutch.com

### Belted Drives

**TB Wood's**  
www.tbwoods.com

### Gearing

**Bauer Gear Motor**  
www.bauergears.com

**Boston Gear**  
www.bostongear.com

**Delroyd Worm Gear**  
www.delroyd.com

**Nuttall Gear**  
www.nuttallgear.com

### Overrunning Clutches

**Formsprag Clutch**  
www.formsprag.com

**Marland Clutch**  
www.marland.com

**Stieber Clutch**  
www.stieberclutch.com

Neither the accuracy nor completeness of the information contained in this publication is guaranteed by the company and may be subject to change in its sole discretion. The operating and performance characteristics of these products may vary depending on the application, installation, operating conditions and environmental factors. The company's terms and conditions of sale can be viewed at <http://www.altramotion.com/terms-and-conditions/sales-terms-and-conditions>. These terms and conditions apply to any person who may buy, acquire or use a product referred to herein, including any person who buys from a licensed distributor of these branded products.

©2017 by Stromag LLC. All rights reserved. All trademarks in this publication are the sole and exclusive property of Stromag LLC or one of its affiliated companies.



[www.stromag.com](http://www.stromag.com)

Hansastraße 120  
59425 Unna - Germany  
+49 2303 102-0